

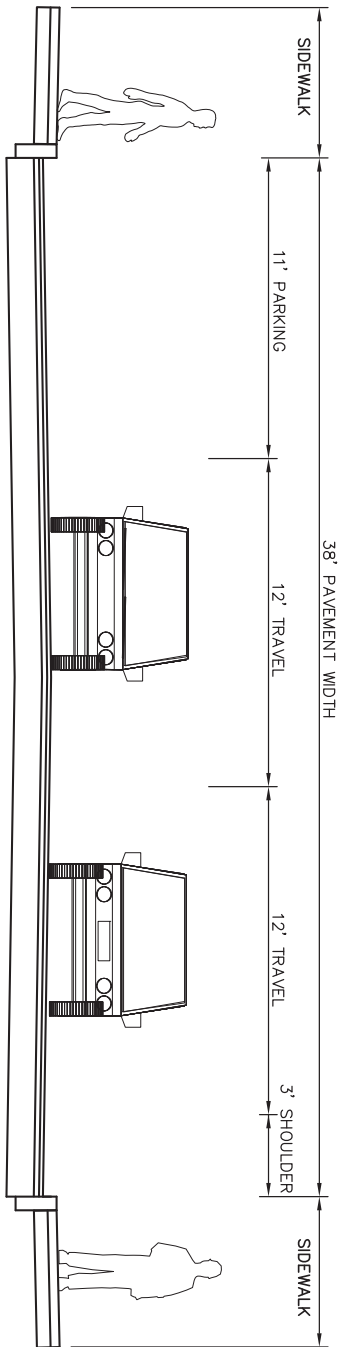

APPENDIX K:
STREET LAYOUTS



**CENTER STREET
PROPOSED 2-WAY TRAFFIC PATTERN**



EXISTING CONDITION



<p>LOCATION 1 CENTER STREET NEAR INTERSECTION OF NONOTUCK AVENUE</p>	<p>CHICOPEE CENTER TRAFFIC PATTERNS PROPOSED 2-WAY TRAFFIC PATTERN CHICOPEE, MASSACHUSETTS</p>
<p>Tighe&Bond Consulting Engineers www.tighebond.com</p>	
<p>SCALE: NONE</p>	<p>DATE: OCTOBER 2011</p>

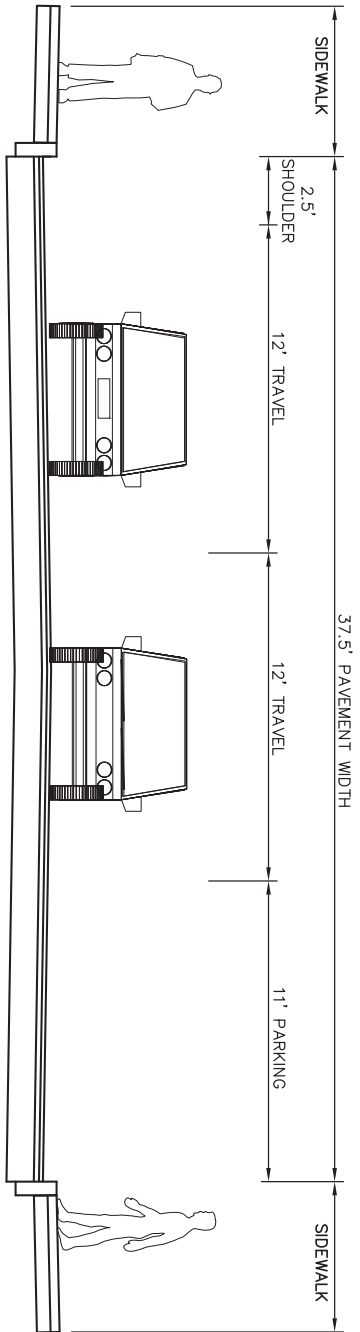

<p>LOCATION 2 CENTER STREET BETWEEN SCHOOL AND EXCHANGE STREETS</p>	<p>Tighe&Bond Consulting Engineers www.tighebond.com</p>
<p>CHICOPEE CENTER TRAFFIC PATTERNS PROPOSED 2-WAY TRAFFIC PATTERN CHICOPEE, MASSACHUSETTS</p>	
<p>SCALE: NONE</p>	<p>DATE: OCTOBER 2011</p>

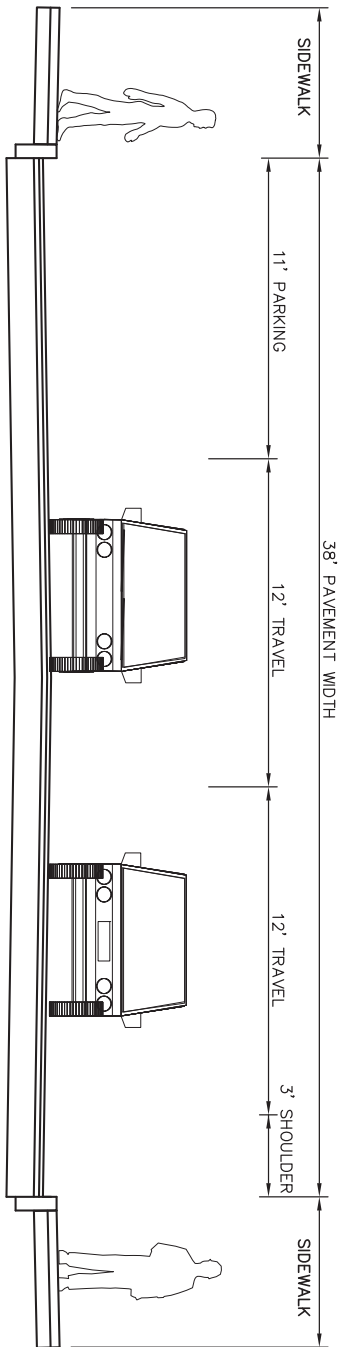

**CABOT STREET
PROPOSED 2-WAY TRAFFIC PATTERN**



EXISTING CONDITION



<p>LOCATION 5 CABOT STREET AT INTERSECTION OF EXCHANGE STREET</p>	<p>CHICOPEE CENTER TRAFFIC PATTERNS PROPOSED 2-WAY TRAFFIC PATTERN CHICOPEE, MASSACHUSETTS</p>
<p>Tighe&Bond Consulting Engineers www.tighebond.com</p>	<p>SCALE: NONE DATE: OCTOBER 2011</p>

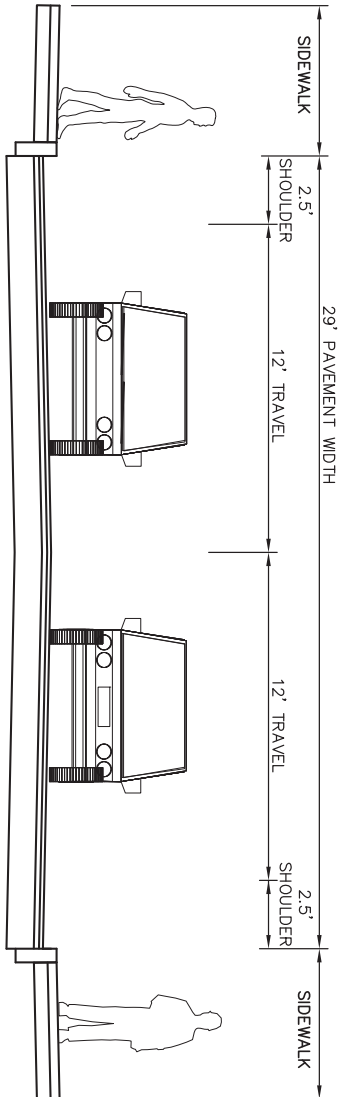

**CABOT STREET
PROPOSED 2-WAY TRAFFIC PATTERN**



EXISTING CONDITION



<p>LOCATION 7 CABOT STREET NEAR INTERSECTION OF PARK STREET & CENTER STREET</p>
<p>CHICOPEE CENTER TRAFFIC PATTERNS PROPOSED 2-WAY TRAFFIC PATTERN CHICOPEE, MASSACHUSETTS</p>
<p>Tighe&Bond Consulting Engineers www.tighebond.com SCALE: NONE DATE: OCTOBER 2011</p>